

Installation Instructions & Users Manual

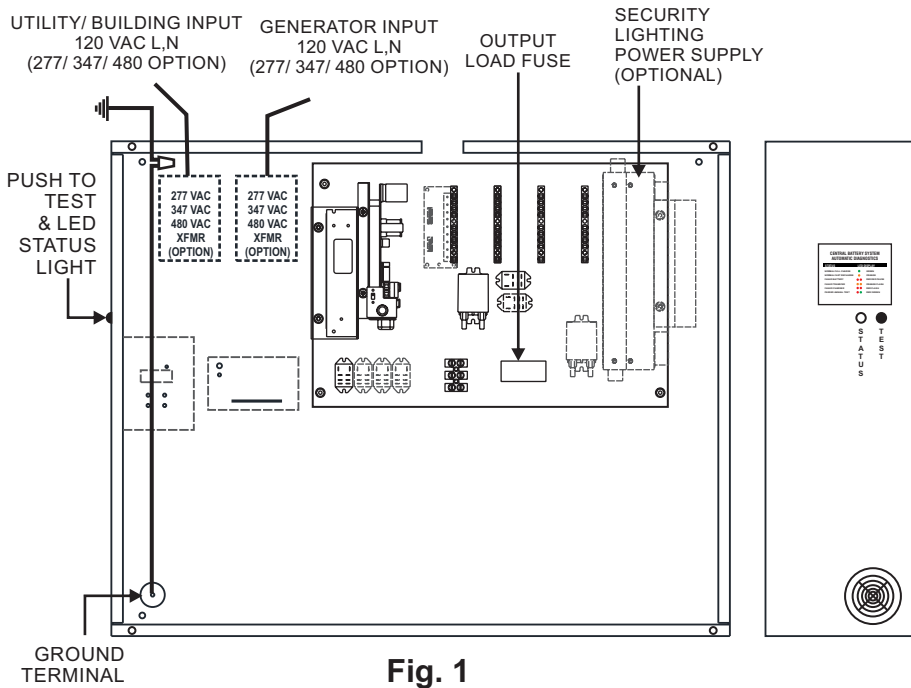

| CBL MODEL | INPUT VOLTAGE | PANEL SIZE H" X W" X D" | WEIGHT** | MOUNT SCREW LOCATION H" X W" |
|-----------|---------------|-------------------------|----------|------------------------------|
| 100 | 120 VAC | 24 x 24 x 8 | 50 lbs.. | 13 x 15 |
| | 277 VAC | 24 x 24 x 8 | 57 lbs. | 15 x 17 |
| 250 | 120 VAC | 24 x 24 x 8 | 75 lbs. | 15 x 17 |
| | 277 VAC | 24 x 24 x 8 | 85 lbs. | 21 x 23 |
| 500 | 120 VAC | 30 x 24 x 8 | 102 lbs. | 15 x 17 |
| | 277 VAC | 30 x 24 x 8 | 135 lbs. | 21 x 23 |
| 1000 | 120 VAC | 30 x 24 x 8 | 200 lbs | 23 x 27 |
| | 277 VAC | 30 x 24 x 8 | 225 lbs. | 23 x 27 |

**Weight includes (2) model specific batteries

Fig. 1

A) PANEL INSTALLATION & AC INPUT WIRING

Refer to **CIRCUIT LAYOUT** and **CIRCUIT LOAD SCHEDULE** for project, if available.

NOTE: This device is a storage battery system for emergency lighting, as described in NEC Section 700.9 and includes Feeder Circuit Equipment. Para (D)(2) of this section states that such equipment should be installed in spaces which are either fully protected by an approved automatic fire suppression system (including sprinklers, carbon dioxide or equivalent systems), or in spaces with a 1-hour fire resistance rating.

- Note the size and weight of panel assembly above. Install (4) screw anchors at the locations shown, on a suitable vertical surface. The preferred mounting height should allow easy access to the panel door for access to internal batteries. Screw anchor size should be rated for the complete panel weight shown.
- For easier access prior to wiring hookup and branch circuit installation, the Control Panel Assembly may be removed from the enclosure by unscrewing (4) #8-32 flanged nuts. Place the panel assembly in safe area and retain the 4 nylon spacers and nuts.
- Make cutouts for required connectors in top surface of enclosure above terminal bars for up to eight (8) emergency branch circuits. See Page 4, Step 4.
- Secure panel enclosure in position. Input AC wiring size should be rated for maximum VA power loading of panel capacity (1000 watts). Install AC wiring for control panel input and optional security lighting inputs as shown. Make connections to labeled internal wiring using standard wire nuts, or to transformer terminals as required.
- Connect AC building service GROUND circuit to screw terminal provided in base of enclosure.

DO NOT CONNECT DC COMMON NEGATIVE TO ENCLOSURE OR AC SERVICE GROUND.

IMPORTANT SAFEGUARDS READ AND FOLLOW ALL SAFETY INSTRUCTIONS

- Disconnect AC power before servicing.
- Refer to wiring diagram for proper connections.
- All servicing should be performed by qualified personnel.
- Consult your local building code for approved wiring and installation.
- Do not use outdoors.
- Do not use this equipment for other than intended use.
- Do not let power cords touch hot surfaces.
- Mount and secure the fixture at a location and height to avoid ready access and tampering by unauthorized persons.
- The use of accessory equipment is not recommended by the manufacturer and may cause an unsafe condition.

SAVE THESE INSTRUCTIONS

B) BATTERY INSTALLATION

- CAUTION!** Only qualified service personnel such as a licensed electrician should perform the battery and DC wiring installation. Always use insulated tools when you work with batteries.
- Full voltage and current are always present at the battery terminals. The batteries used in the system can produce dangerous current and may cause severe injury if the terminals are shorted together or to ground (earth). Do not touch uninsulated battery terminals or contact terminals with a metal object that could short to dead metal or any exposed electrical terminal or component, which could damage equipment and void manufacturer's warranty.
- See figure 2 Page 3. Place batteries in base of enclosure with positive and negative terminals in the positions shown below. Connect wiring to battery terminals. Each wiring harness is numbered 1 thru 4 to match positive and negative battery terminals. Do not reverse polarize any terminal.

NOTE: With AC supply OFF, the system will be in emergency mode when all battery terminals are connected. LCD display will activate (blank) and emergency output terminals will be live 24 VDC.

- If batteries are fully discharged under load and AC supply remains OFF, disconnect batteries by removing one battery terminal, until AC supply is ON. Microchips controlling timers on the main circuit control board draw a small continuous current, which can cause deep discharge after an extended period, especially if ambient temperatures are above normal.

BATTERY SPECIFICATIONS

| CBM OUTPUT POWER (WATTS) | BATTERY P/N | CAPACITY (AMP-HR) | DIMENSIONS L x W x D (INS) | TERMINAL TYPE |
|--------------------------|-------------|-------------------|----------------------------|---------------|
| 100 | UB1280 | 8 | 5.9 x 2.6 x 3.7 | F1 |
| 250 | UB12260 | 26 | 6.6 x 6.9 x 5.1 | M6 NUT/BOLT |
| 500 | UB12500 | 50 | 7.7 x 6.5 x 6.9 | M8 NUT/BOLT |
| 1000 | UB121000 | 100 | 12.9 x 6.8 x 8.6 | M10 NUT/BOLT |

TOP VIEW IN ENCLOSURE

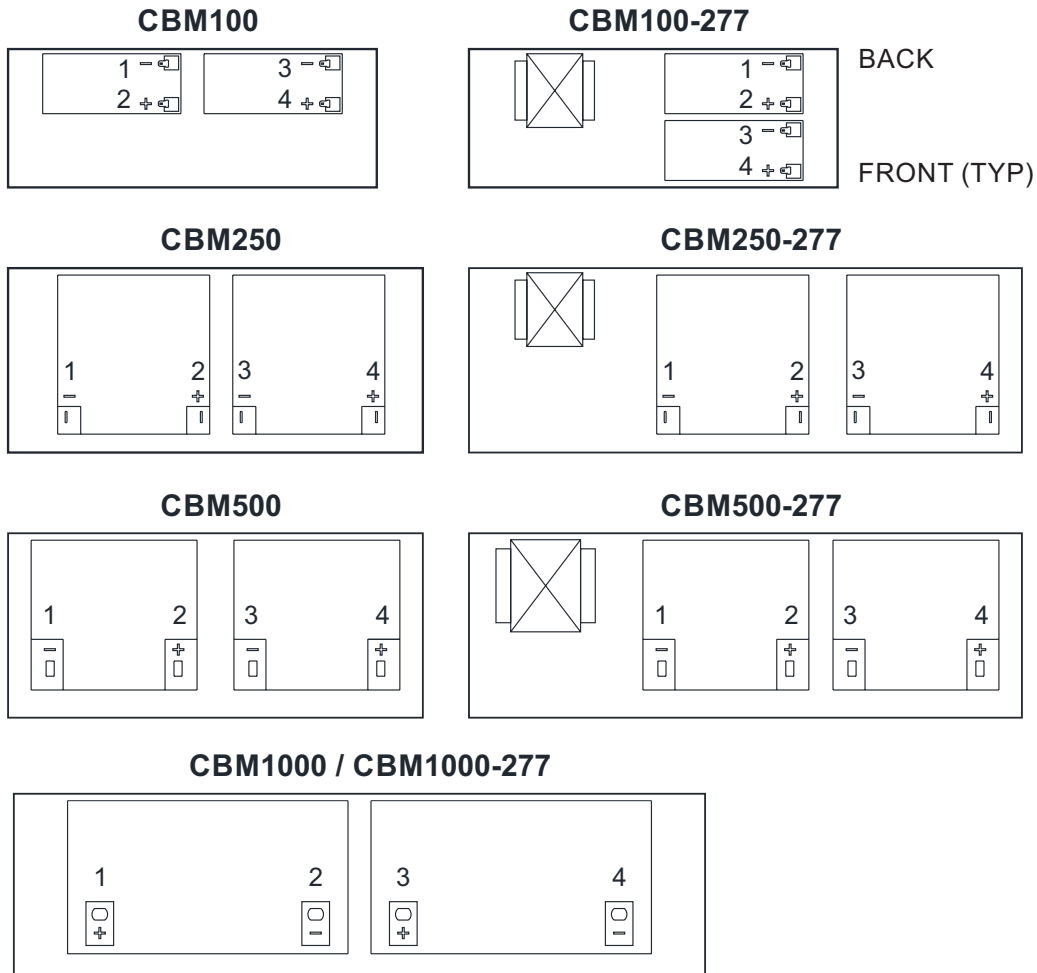

**C) NO LOAD OPERATION TEST:
 NO EMERGENCY CIRCUITS OR FIXTURES CONNECTED**

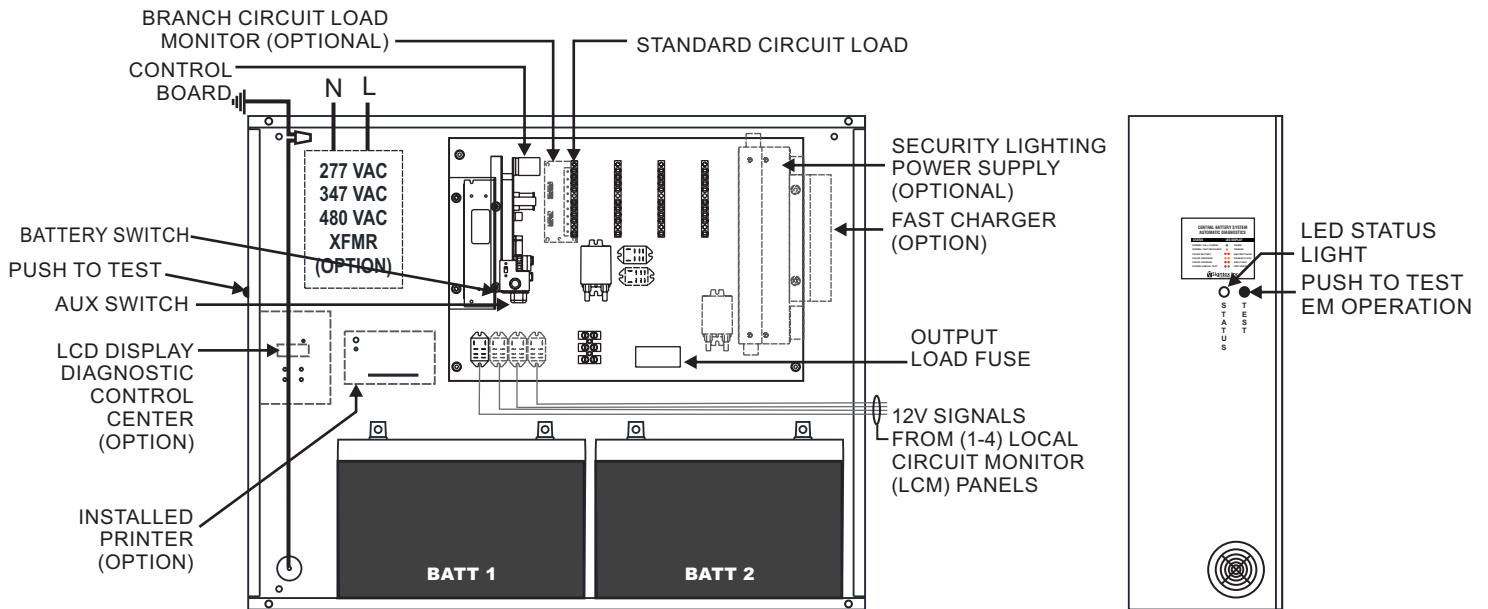
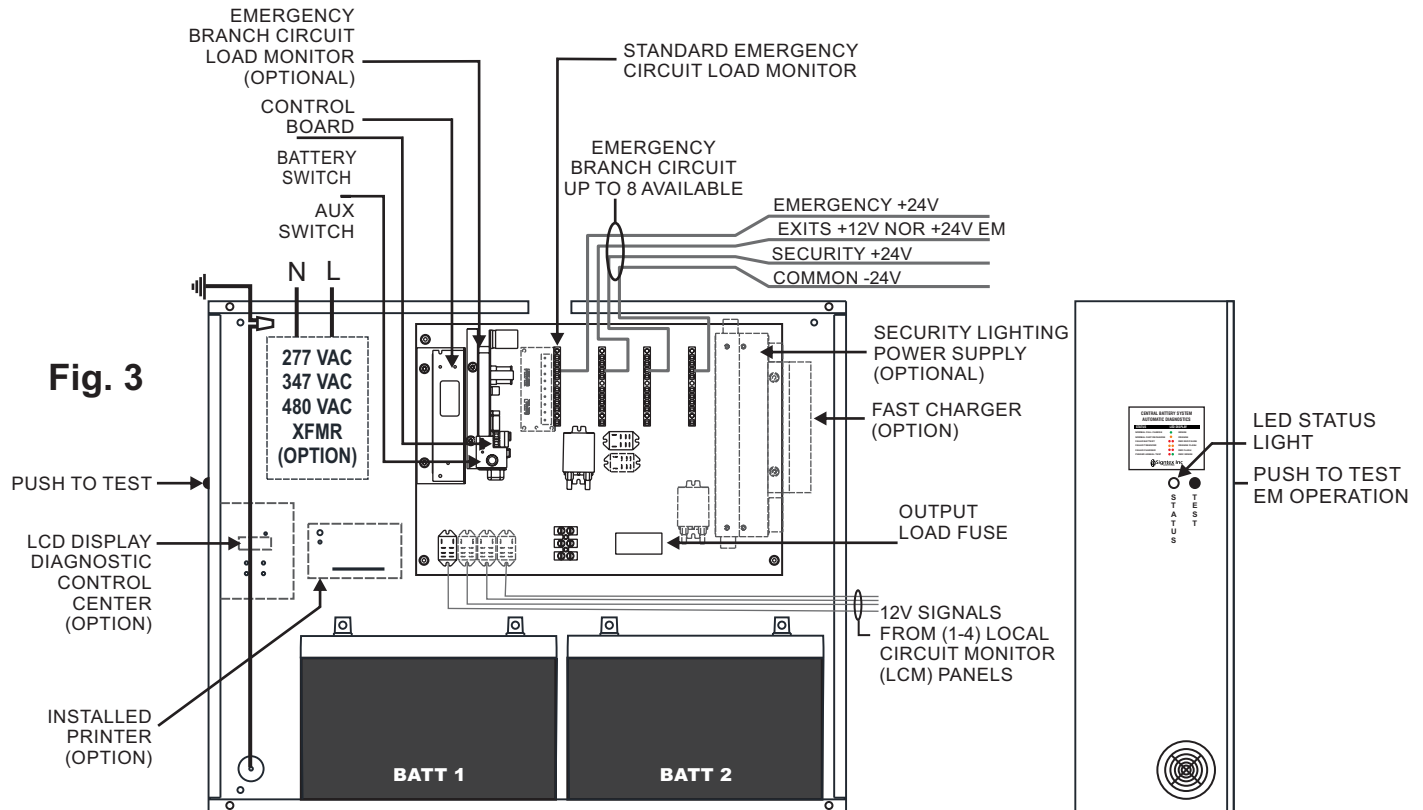

Fig. 2

1. See Fig. 2. Battery switch should be ON. Ensure all AC connections are complete and turn building AC supply ON. Status LED on side of panel should illuminate steady ORANGE, GREEN or Flashing ORANGE.
Note: The Flashing ORANGE status code indicates no load detected and should be persist until branch circuits are installed(see section D).
2. With voltage meter set to 12-24VDC range, measure voltage between COMMON NEGATIVE (BLACK) and EXIT/CVRE . Meter should read 12VDC \pm 2V.
3. Press and hold PUSH to TEST (PTT) button; Status LED should turn OFF, transfer relay should operate. Release PTT button; the status LED should turn back ON.
4. Locate RED button marked "AUX". Press the button three times rapidly to activate ANNUAL TEST. System will transfer to emergency operation and remain in ACTIVE EMERGENCY MODE for 90 minutes, or until reset.
5. Measure Voltage between COMMON NEGATIVE and EMERGENCY terminal bar (RED): should read 24VDC \pm 2V).
6. Interrupt Annual Test and reset the system: Disconnect 2-pin AC input plug at circuit board for 5 seconds, then reconnect. Alternatively, turn AC utility supply OFF for 5 Seconds at supply panel, then turn ON.
7. System will now remain in BATTERY CHARGE mode.

D) BRANCH CIRCUITS & SYSTEM TESTS



1. See Fig. 3. Disconnect battery by moving BATT slide switch to OFF position.
2. Review circuit layout documents for wire size required (18AWG to 8AWG) and number of conductors (2-4 per circuit) depending on the fixture and circuit layout configuration. Install connectors and route wiring for up to eight (8) branch circuits into enclosure and connect to terminal bars.
 Maintain color codes on each circuit from Panel to fixtures. **Cross connection between any of the four conductors will cause improper operation or failure of components.**
3. Set OHM meter on High range. Confirm you have OPEN CIRCUIT readings between any branch circuit conductor and EARTH (AC) GROUND.
4. Connect all COMMON NEGATIVE RETURN conductors to BLACK terminal bar. Confirm you have OPEN CIRCUIT readings between COMMON NEGATIVE RETURN and EXIT, EMERGENCY and SECURITY conductors. Check wiring continuity through all fixtures on the circuit. Connect all COMMON conductors to the marked COMMON NEGATIVE terminal bar, set OHM meter to MEDIUM RANGE (1-5K ohm) and confirm meter reading as follows:
 - (a) Fixtures with ELC (Emergency Lighting Control): NOT LESS THAN 50 ohm.
 - (b) MOONLITE LED fixtures and Exits: OPEN CIRCUIT or NOT LESS THAN 5K ohm.
5. When all branch circuits are connected and checked, **MOVE BATT SLIDE SWITCH TO ON. ALLOW TO CHARGE AT LEAST 24 HRS BEFORE TESTING EMERGENCY FIXTURES.** Full charge may require from 24-72 hrs depending on Model: refer to label on Charger Board for required charge time.
6. **Emergency Lighting Operation:** Momentarily press button marked AUX three times rapidly (three presses in less than 2 seconds). System will remain in ACTIVE EMERGENCY MODE for 90 minutes annual test unless RESET. Inspect all emergency fixtures and confirm operation in emergency mode. Annual test can be terminated anytime by disconnecting AC supply to control board for at least 5 seconds and then reconnect.
7. **Datum Load Current Setting:** Press PUSH TO TEST button on outside of Panel and hold, then press AUX button for 5 seconds to insert the full load current value into the processor memory. Status LED will flash rapidly: RED- PAUSE-GREEN- PAUSE to indicate the programming has taken place; this will cease when the button is released.
8. **System RESET:** Disconnect batteries by removing battery terminal #1 or #4 and turn AC utility supply OFF for 5 seconds, then turn ON. Alternate method: disconnect AC supply 2- pin plug to control board inside panel for 5 seconds, then reconnect.

E) Security / Night Lighting Wiring Options

1. Security Lighting with Timer Control.

NOTE: IF EM SUPPLY IS 120 VAC, THIS CIRCUIT CAN ALSO FEED TIMER CONTROL SWITCH. IF EM SUPPLY IS 277 VAC, TIMER CONTROL REQUIRES SEPARATE CIRCUIT

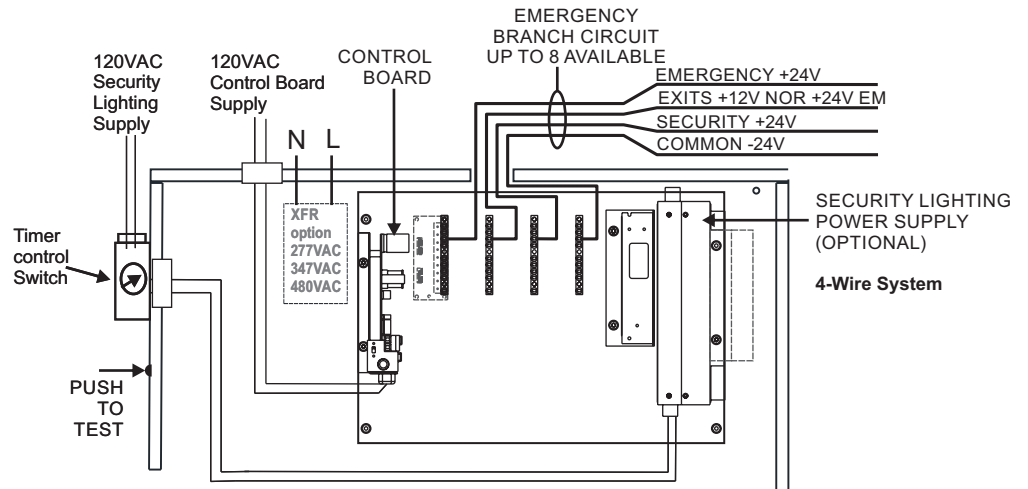

2. Security Lighting with Optional internal Control.

NOTE: LCD OPTION IS REQUIRED FOR INTERNAL SEC CONTROL.

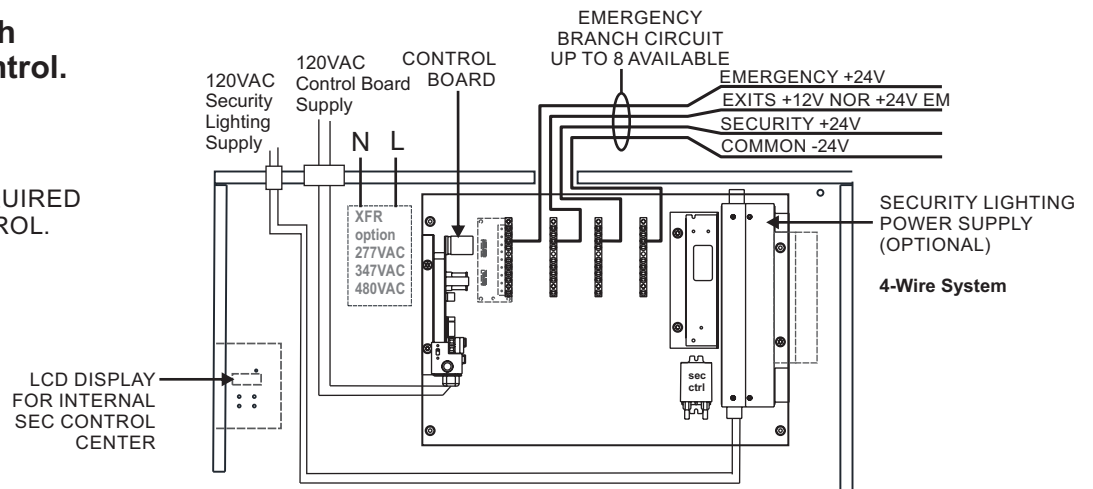

3. Security Lighting With External Switch Control.

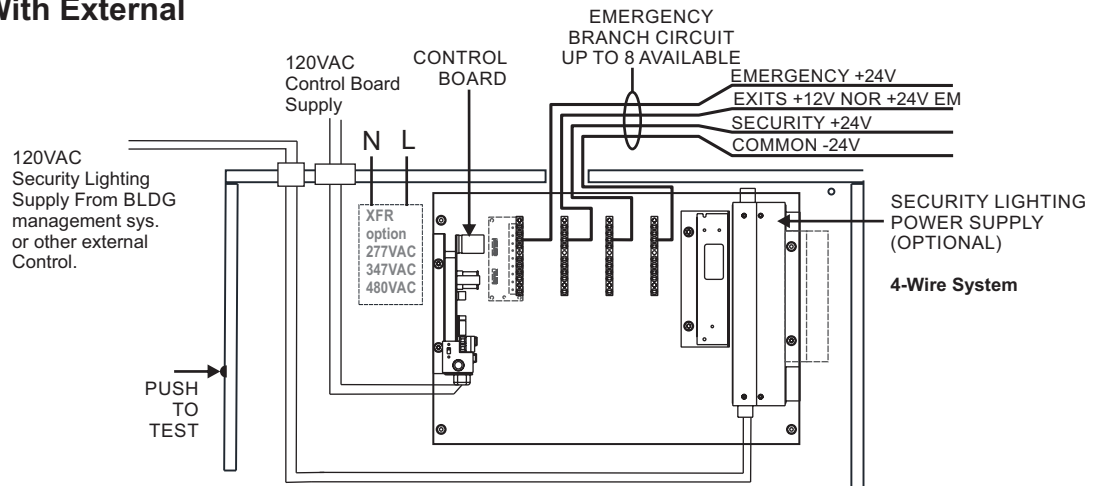

F) LOCAL CIRCUIT MONITOR (LCM) & FIRE ALARM INTERFACE (FAI) WIRING

Fig. 4

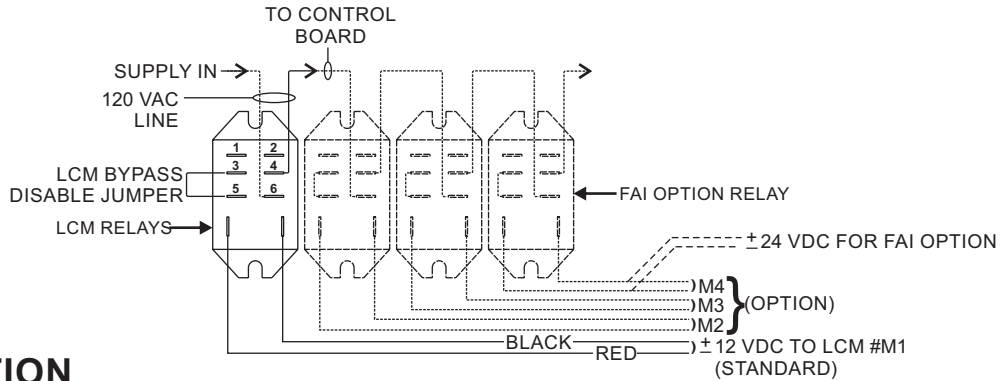

LCM OPERATION

1. Refer to LCM Installation Instructions and User's manual for LCM Panel installation.
2. Route 12V wiring from LCM Panel(s) into CBL enclosure as shown in Figs 3 and 4 and connect to pigtailed provided on LCM relay. Each input circuit should be marked with appropriate LCM Panel Number.
NOTE: Leave all DISABLE JUMPERS in place until LCM panels are active with all AC monitored circuits ON and 12V signal is ON at relay inputs.
3. **Activate all monitored AC branch circuits at LCM Panels and confirm 12V signal is ON.** Remove DISABLE JUMPERS on all LCM relays.
NOTE: If 12V signal is OFF with Jumpers removed, system will lock in emergency mode at full load.

FAI OPTION

FAI relay replaces LCM relay in position #4. Connect 24V supply leads to FAI relay, confirm 24V FAI signal is ON, then remove DISABLE JUMPER from FAI Relay.

G) SELF- TEST DIAGNOSTICS

Turn AC power ON. The LED status indicator will illuminate and should initially illuminate steady AMBER (high charge rate). Upon reaching full charge, the indicator will change to steady GREEN (low charge rate). The LED Status Indicator will show the following:

| TEST FUNCTIONS | NORMAL or PASS | FAULT |
|-----------------------|-----------------------|--|
| Battery | GREEN OR AMBER | RED- RED- PAUSE |
| Transfer Switch | No indication | ORANGE FLASH |
| Charger Status | No indication | RED FLASH |
| Connected Load Status | No indication | GREEN FLASH |
| 30 Day Test | No indication | Indication as above for specific fault |
| Annual Test | RED-GREEN Alternating | Indication as above for specific fault |

CHARGE RATE

| | |
|--------------|---------------|
| Float Charge | STEADY GREEN |
| Bulk Charge | STEADY ORANGE |

The standard CBL system will automatically perform the following system tests:

MONTHLY TEST: 30 SEC FULL LOAD OPERATION

Battery Condition Transfer Switch Operation Battery Charge Rate Connected Load Continuity

ANNUAL TEST: 90 MIN FULL LOAD OPERATION

12 months from the date of installation, an annual test is required by initiating full operation of the emergency load for 90 minutes, in compliance with NFPA Life Safety Code 101.

(1) **Standard System:** Periodic diagnostic tests will start at the same time the system was first activated with AC power.

NOTE: To avoid operation of emergency lighting at potentially undesirable times, automatic operation can be disabled by specification of Option "NAT", as designated in the Model Number Label. If such option is supplied, the annual test must be activated manually, per below.

(2) **LCD Test Panel Option:** This option includes a Real Time Clock which can be set to initiate the diagnostic tests at the user's selection.

MANUAL INITIATION OF ANNUAL TEST

Momentarily press and release the AUX button located next to the Charger Control Board **three times rapidly**. The system will then operate the full connected emergency load for 90 minutes for the Annual Test. The annual test can be interrupted anytime by using Reset Procedure per below.

Upon completion of the annual test, if NO FAULTS are detected the system will reset automatically. If a FAULT is detected, repair or replacement is required and after repair, the system will require a RESET PROCEDURE (see below).

RESET PROCEDURE

Turn AC power OFF Wait 5 seconds Turn AC power ON

TESTING ALL EMERGENCY LOADS

Press the PUSH TO TEST button to operate all fixtures in emergency mode as long as the button remains depressed, or 30 seconds operation when button is released. Lamps can be checked visually during this period. Alternatively; (a) AC power to the panel may be interrupted by qualified personnel to allow a comprehensive check by one person of all connected loads, or (b) the Annual Test may be activated as described above.

FAILURE MODES & CORRECTIVE ACTIONS

30 day Test or Annual Test FAIL:

Indicates that one or more of the four (4) TEST FUNCTIONS failed during the test.

Battery State Alarm (FLASHING RED-RED -PAUSE):

One or both batteries' terminal voltage has dropped below 10.5V in less than 90 minutes since loss of AC line power, OR is below 10.5V at any time in normal operation.

CORRECTIVE ACTION: Replace BOTH Batteries

NOTE: (1) To avoid unnecessary replacement, make sure the batteries have completed their full charging cycle.
(2) Always replace both batteries, not one. Low voltage in one battery may affect the second battery.

Transfer Switch Alarm (FLASHING ORANGE):

Failure to transfer connected load to battery power when AC line power fails.

CORRECTIVE ACTION: To confirm the fault code is correct, reset the system by depressing PUSH TO TEST for approximately 5 Seconds. If the error returns, the circuit board must be replaced. Note your CBL SERIAL and MODEL number located inside of the CBL box and then contact to the factory.

Charger State Alarm (FLASHING RED): Battery charge current has fallen below a threshold value.

CORRECTIVE ACTION: Same as Transfer Switch fault.

Connected Load Alarm (GREEN FLASH)

- (1) Total Load Monitoring: Total Connected load has changed more than 10% compared to value at initiation (current datum set)
- (2) Branch Circuit Load Monitoring (NOTE: Requires LCD Test Panel Option): Connected load in a single emergency branch circuit has changed by more than 10% compared to the value at initiation.

CORRECTIVE ACTION: Activate emergency mode by either turning AC power supply OFF, OR manually initiate ANNUAL TEST as described above. Visually check for inoperative or partially inoperative emergency fixtures. For systems with LCD option, check branch circuit as identified on the display. Repair or replace any fixture or circuit found inoperative.

BATTERY SERVICE

When installing or replacing batteries, install or replace with same number and type or equivalent model. The battery can present a risk of electrical shock and high short circuit current. Following precautions should be observed before replacing the battery.



- Wear rubber gloves and boots.
- Remove rings, watches and other metal objects.
- Use tools with insulated handles.
- Do not lay tools or other metal objects on the batteries.
- If the battery is damaged in any way or shows signs of leakage, contact your local representative immediately.
- Do not dispose of batteries in a fire. The batteries may explode.
- Handle, transport and recycle batteries in accordance with local representative.
- It is highly recommended that a qualified electrician make all power connections.

General Specifications

- 12V Sealed Lead Acid (SLA), Valve Regulated
- UL Recognized Equipment
- AGM construction
- Minimum Operating Temperatures:
- Charging: 0C to 40C
- Discharging: -15C to 45C

Electrical and Mechanical Specifications

| CBL OUTPUT POWER (WATTS) | BATTERY P/N | 20-Hr CAPACITY (Amp-Hr) | DIMENSIONS L x W x D (INS) | TERMINAL TYPE |
|--------------------------|-------------|-------------------------|----------------------------|---------------|
| 100 | 220041 | 8 | 5.9 x 2.6 x 3.7 | F1 |
| 250 | 220625 | 26 | 6.6 x 6.9 x 5.1 | M6 NUT/BOLT |
| 500 | 220350 | 50 | 7.7 x 6.5 x 6.9 | M8 NUT/BOLT |
| 1000 | 220524 | 100 | 12.9 x 6.8 x 8.6 | M10 NUT/BOLT |

Suppliers

| Suppliers | 8 Ah, 12V (CBL-100) | 26 Ah, 12V (CBL-250) | 50 Ah, 12V (CBL-500) | 100 Ah, 12V (CBL-1000) |
|-------------|---------------------|----------------------|----------------------|------------------------|
| Universal | UB-1280 | UB-12260 | UB-12500 | UB-121000 |
| Power Sonic | PS-1280 | PS-12260 | PS-12500 | PS-121000 |
| NPP Power | NP12-8Ah | NP12-26Ah | NP12-50Ah | NP12-100Ah |
| CASIL | CA-1280 | CA-12260 | CA-12500 | CA-121000 |
| APEX | APX-1280 | APX-12260 | APX-12500 | APX 12-100S |

REPLACEMENT PROCEDURE

1. Turn Battery Disconnect switch OFF, located inside CB box (refer to fig. 5).
2. Remove old batteries by disconnecting terminals from 1 to 4.
3. Secure terminals ends with electric insulation tape.
NOTE: DO NOT SHORT TERMINAL WITH EACH OTHER OR WITH THE METAL ENCLOSURE
4. Install new batteries according to your CB model as shown in the following diagrams. Make sure proper polarity is observed.
5. Turn ON Battery Disconnect switch to the original position.

BATTERY CARE, HANDLING & MAINTENANCE

1. DO NOT leave batteries over 90 days without charging.
2. If batteries are fully discharged under load and AC power remains OFF for an extended period and charger is not operating, DISCONNECT the batteries by removing one of the terminals, and reconnect when AC power returns.
3. If batteries are stored, recharge the batteries every 90-120 days.
4. Batteries maintain optimum performance at 25 °C (77°F). Higher temperatures Reduce battery life. At about 35°C (95°F) battery life is half the life at 25 °C.

Battery Disconnect switch

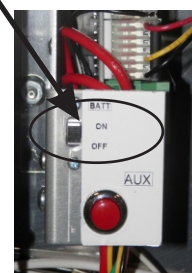
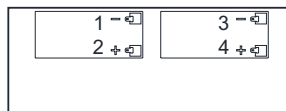
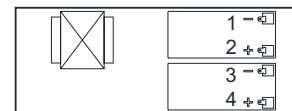

Fig. 5

CBL100



CBL100-277



Front

CBL250

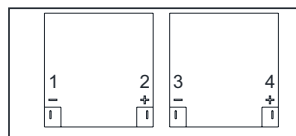

CBL250-277

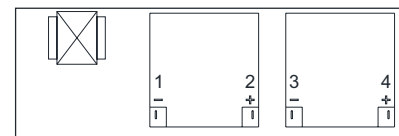

TOP VIEW IN ENCLOSURE

Battery terminals are marked in all CB units. When connecting batteries, you must connect the batteries according to your model diagram as shown. If you have further questions about battery connections please contact to Sigtex Tech Support at (410)-827-8300 Or Email at techsupport@sigtexinc.com

CBL500

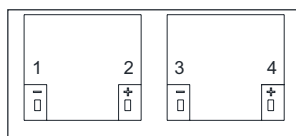

CBL500-277

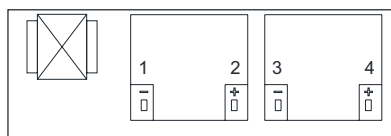

CBL1000 / CBL1000-277

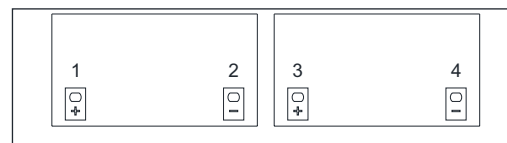

G) TROUBLESHOOTING

| STATUS LED | Possible Cause | Recommended Solution |
|-------------------------|----------------------|--|
| OFF | NO AC | Check to make sure either 120VAC or 277VAC input power is connected to the proper terminals at the CBL system. Verify input voltage with a voltmeter. If there is input power, but not on the Charger Board 2 pin AC connector (Black and White wiring) then check your LCM connection to confirm 12V at the LCM relay (Refer to Install Instructions, LCM Section). |
| | TEST Mode | Interrupt the test by removing 2 pin AC disconnect plug for 5 seconds, then reconnect to RESET test program. If the system still stays in emergency, check AC connections and LCM input. |
| | Battery switch OFF | Turn ON the BATTERY SLIDE SWITCH on Charger Board. |
| FLASHING RED-RED -PAUSE | Battery Disconnected | Check to make sure that all four battery terminals are properly connected to both batteries as shown in Page 2. |
| | Low Battery Alarm | One or both batteries' terminal voltage has dropped below 10.5V in less than 90 minutes since loss of AC line power, OR is below 10.5V at any time in normal operation |
| FLASHING GREEN | Load Monitor Alarm | No load has been setup on the CBL system. Follow the the instructions on page 4, step 7 to setup a datum current setting. |
| | Connected Load Fail | Total Connected load has changed more than 10% compared to value at initiation. Check to make sure that all fixtures lights up. Try to reset your Datum current. |
| FLASHING RED | No Charger Current | To confirm the fault code is correct, reset the system by depressing PUSH TO TEST for approximately 5 seconds. If the error returns, the circuit board must be replaced. |
| FLASHING AMBER | Transfer Failed | Reset DATUM LOAD CURRENT as Shown on Instructions Page, 4 then reset the system by depressing PUSH TO TEST for approximately 5 seconds. If the error returns, the circuit board must be replaced. |
| ALTERNATING RED-GREEN | Annual Test PASS | This is correct signal to warn that written report is required. Reset the system by depressing PUSH TO TEST for approximately 5 seconds. |
| STEADY AMBER | Bulk Charge | Batteries are in Charge mode. Annual 90 min Test is flagged OFF until full charge is completed, when LED turns to STEADY GREEN. |
| STEADY GREEN | Normal Charge | No Action needed. System is ready for any test. |

NOTES

