

Universal Central Emergency & Standby System For all Sigtex Emergency Lighting Products

Series CES
CES.01.12.02

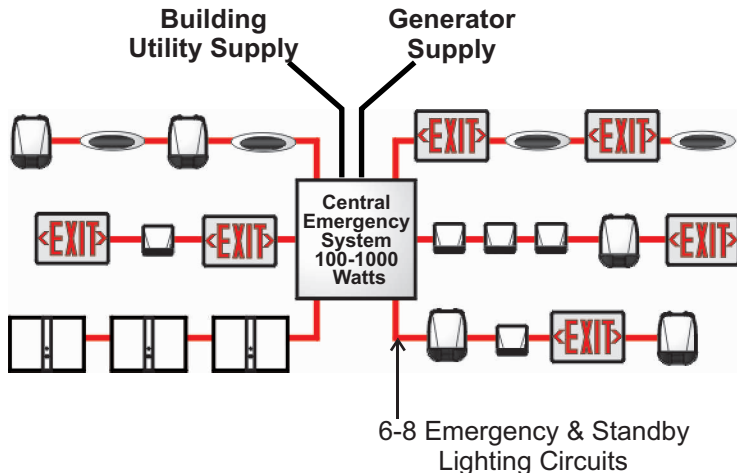

GENERAL DESCRIPTION

Upon failure of normal building power, the CES will supply from 100 to 1,000 watts of continuous power for standby lighting in accordance with NEC Article 701.11(B), with source power supplied from a generator. Standby lighting provided by Sigtex MOONLITE LED emergency lighting fixtures will provide an average of 1Fc minimum along the path of egress. Upon failure of both normal and generator power, the CES panel will supply up to 1,000 watts of power from storage batteries for a minimum of 90 minutes, providing an average of 1Fc minimum initial brightness along the path of egress. Feeder circuits to the CES panel may be installed in accordance with NEC 701.10 and permitted to occupy the same raceway, cables, boxes and cabinets with other general wiring.

CONSTRUCTION & OPERATION

- Uninterruptible Power Supply for Standby and Emergency lighting in compliance with NEC 701.11 (A) and (B), with standby power supply, storage batteries, charging system, automatic transfer switch and self-test switch with LED status indicator.
- Dual AC input circuits from normal building supply and generator standby supply.
- NEMA Type 1, UL 50 steel cabinet, for surface or optional recessed mount
- Test switch and diagnostic status indicator allow immediate update on battery condition and charger performance.
- Up to eight low voltage circuits operate emergency lighting and standby lighting, and exit signs. Fixtures may be connected together in parallel in a "daisy-chain".

ELECTRONICS

- INPUT: 120 VAC standard, 277 VAC optional; normal mode (CHARGING) current: less than 5A.
- OUTPUT: 24 VDC: Six (6) branch circuit terminal connections provided with an option for (8) circuits.
- Service load range for Standby Lighting from 4.2A (CES100) to 42A (CES1000).
- 4 conductors required for standby and emergency operation of exit signs and lighting fixtures. Typical conductor wire size: 10-12 AWG
- All charger functions are monitored by an advanced microprocessor which also automatically performs all self-test diagnostics as required by NFPA 101 and UL 924, every 30 days and every 12 months following installation.
- Output terminal blocks, accept wire gauges from 16 AWG to 8 AWG.

BUILDING MANAGEMENT INTERFACE

- An optional BMI module allows communication of diagnostic data between a CBS panel and a Building Management System via BACnet protocol, or equivalent code. Written test reports can be produced in full compliance with the NFPA Life Safety Code 101, Section 7.9.3.1.3 (5).

CODES

- Meets applicable requirements of UL Standard 924, NFPA 101, and NEC 701.11(B).

FIXTURE SCHEDULE

MODEL	CATALOG NO
APPROVAL	JOB INFORMATION



Universal Central Emergency & Standby System For all Sigtex Emergency Lighting Products

Series CES
CES.01.12.02

SUGGESTED SPECIFICATIONS:

Power for emergency lighting shall be provided by Sigtex Inc Central Emergency and Standby System Series CES, with input of 120 VAC or optional 277 VAC and uninterrupted output of 24 VDC for loads as specified for at least 90 minutes in emergency operation. The system shall be capable of supplying power to all Sigtex emergency lighting remote fixtures, including COVERLITE and MOONLITE™ models, and all LED exit signs. Panel construction shall be from sheet steel, UL listed, and meet NEMA 1 requirements. Battery diagnostics will perform automatic testing as required to meet national and local codes, and status will be displayed with a multicolor LED on the panel, and manual push-to-test switch. An optional Building Management Interface (BMI) shall be capable of communicating diagnostic self-test data to Building Management System.

CES PANEL LAYOUT & DIMENSIONS:

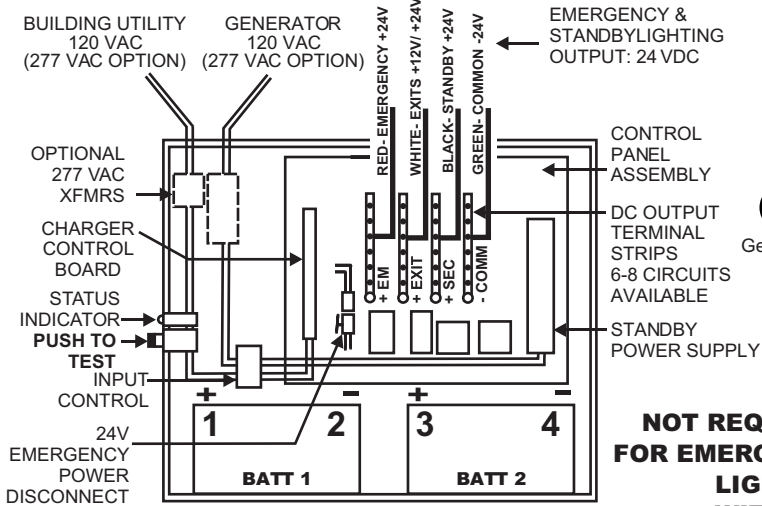

EPR & SBY WATTS	PANEL SIZE H" x W" x D"	WEIGHT WITH BATTS Lbs.
100	16 x 16 x 6	42
250	18 x 18 x 8	62
500	18 x 18 x 8	105
1000	20 x 24 x 8	185

KEY

G- GREEN: COMMON / GND: 24 VDC NEG -
W- WHITE: EXITS AND CVRE: 12-24 VDC POS +
R- RED: EMERGENCY POWER: 24VDC POS +
B- BLACK: STANDBY POWER: 24 VDC POS +

EPR= POWER TO DRIVE EMERGENCY LIGHTING FOR 90 MINUTES
SBY= POWER AVAILABLE FOR CONTINUOUS SECURITY LIGHTING
Panel size may vary from table above. Contact factory for dimensions.

CIRCUIT LOAD CALCULATIONS

- Up to eight circuits are available from each central emergency system panel.
- Any Sigtex REMOTE model may be connected to the system, within the power limits of the central emergency system.
- To calculate loads with multiple circuits, refer to www.sigtexinc.com/CBS/DesignGuide.

ORDERING INFORMATION

EXAMPLE: CES250277

CES	250	277
MODEL		
CES		
90 MINUTE OUTPUT WATTS	100	
	250	
	500	
	1000	
OPTIONS		
		SEE ABOVE

OPTIONS

- EX** Additional Exit Lighting¹
- BMI** Building Management Interface
- CVR** Output Power Relay for CVRE Operation
- 277** 277 VAC Input for Charger System
- REC²** Recess Mount
- LOK** Key Lock
- 8BC** Add 2 DC Output Terminals

¹CES100, CES250 and CES500:
STANDARD: MAX. 15 EXIT SIGNS PER CES
²"EX" OPTION: MAX. 40 EXIT SIGNS PER CES
CES1000 STANDARD: MAX. 40 EXIT SIGNS PER CES
³Limited sizes available. Contact factory for information.

TYPICAL CES EMERGENCY LIGHTING SYSTEM

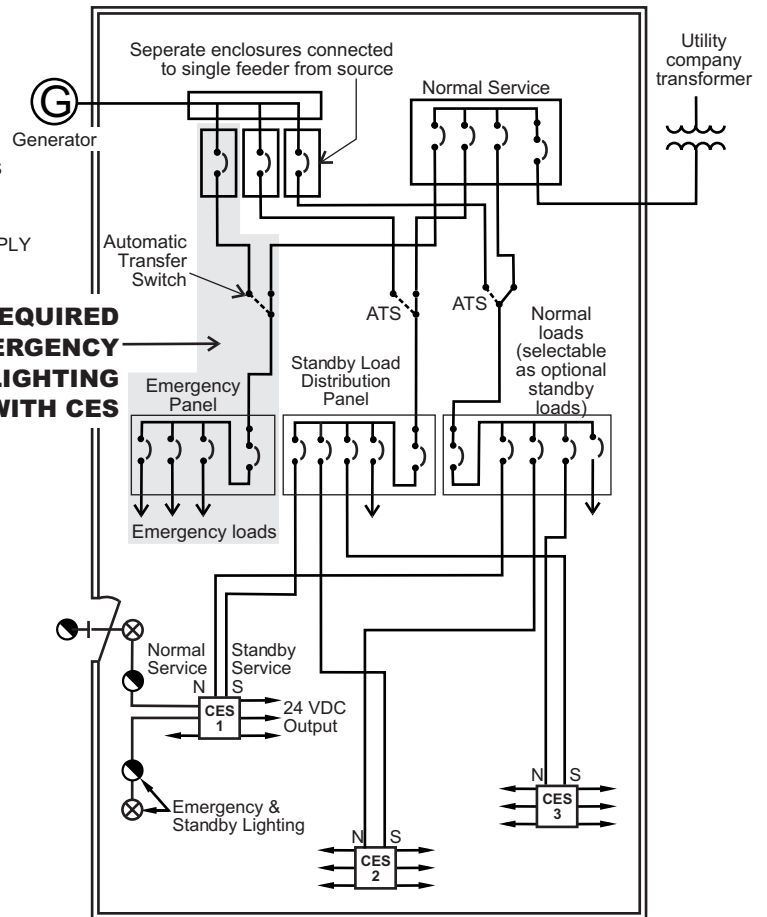

As shown above, and emergency feeder circuit from the generator, emergency ATS and emergency panel are not required for emergency lighting using the Sigtex CES. Other emergency loads may require an emergency circuit from the generator.

CES EMERGENCY & STANDBY OPERATION

- UTILITY ON, STANDBY OFF: Normal operation, emergency lights OFF
- UTILITY OFF, STANDBY ON: Emergency Lights ON, powered by generator STANDBY circuit
- UTILITY OFF, STANDBY OFF: Emergency Lights ON, Powered by batteries for 90 mins.

DISTRIBUTOR:



Sigtex Inc
LIGHTING

220VFW Avenue, Grasonville, MD 21638
TEL: (410) 827-8300 Fax: (410) 827-8866
sales@sigtexinc.com www.sigtexinc.com