

# Rapier

Open Face

## Diecast LED System Series RPRO

### INSTALLATION INSTRUCTIONS AND OWNER'S MANUAL

## IMPORTANT SAFEGUARDS READ AND FOLLOW ALL SAFETY INSTRUCTIONS

Before connecting to power supply, TURN OFF ELECTRICAL  
POWER AT CIRCUIT BREAKER OR FUSE

Disconnect AC power before servicing.

Refer to wiring diagram for proper connections.

All servicing should be performed by qualified personnel.

Consult your local building code for approved wiring and installation.

Do not use outdoors.

Suitable for indoor damp locations (when specified).

Do not let power cords touch hot surfaces.

Do not mount near gas or electric heaters.

Mount and secure exit sign at a location and height to avoid  
ready access and tampering by unauthorized persons.

(Exception: Floor proximity installations)

The use of accessory equipment is not recommended by  
the manufacturer and may cause an unsafe condition.

Do not use this equipment for other than intended use.



## SAVE THESE INSTRUCTIONS

Before installing or connecting any primary power wiring,  
**DISCONNECT MAIN POWER SUPPLY AT THE CIRCUIT BREAKER OR FUSE.**

**ALL INSTALLATIONS REQUIRE STANDARD TYPE 4" x 4" SQ x 2 1/8" DEEP J- BOX.  
SET ADAPTOR PLATE 1/4"- 3/8" BELOW FINISHED PANEL SURFACE**

## WALL MOUNT

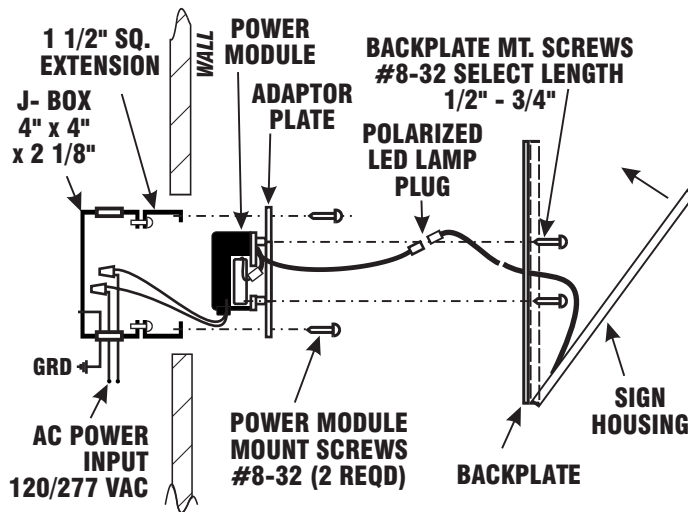

DRILL OUT 3/16" DIA IN TWO PLACES TO MATCH J-BOX LOCATION  
PUNCH SUPPLIED TO REMOVE K.O. FOR WIRING

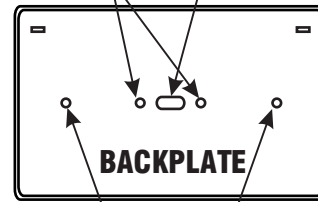

DRILL 3/16" IN TWO PLACES FOR ADDITIONAL WALL MT. SUPPORTS USING SCREW ANCHORS

## WALL MOUNT

1. Install J-Box 1/8"-1/4" below finished panel surface. Connect Power Module AC wiring to building supply in J-Box, using wire nuts or connectors supplied. BLACK: 120 277 VAC  
WHITE: Common.
2. Route wire nuts to side of J-box, insert Power Module into box and secure with 2 #8-32 box screws.  
NOTE: Power module orientation is universal, position as required to clear connectors and wire nuts in J-box.
3. Remove back plate from sign assembly by inserting pin (small screwdriver or allen key) into 2 release holes in top edge, press down to release clips and hinge cover away from housing.
4. Using punch supplied, support backplate on raised flat surface and knock out oval opening in center  
NOTE: Remove any sharp edges around opening by file or sharp metal blade. Drill 3/16" diameter holes at locations noted above. For additional support drill out 2 additional 3/16" dia holes at left and right sides on center. Locate back plate in position on wall and mark support holes; install wall anchors for support screws.
5. For battery backup models, connect 2-pin polarized battery plug.
6. Run LED lamp plug through backplate. Attach back cover to j-box with 2 #8-32 screws supplied. Install and tighten 2 support screws. DO NOT OVERTIGHTEN.
7. Insert 2 tabs on base of sign assembly into slots in base of back cover. Connect LED lamp plug.
8. Hinge sign assembly into position and snap closed.

To remove signs, repeat step 3.

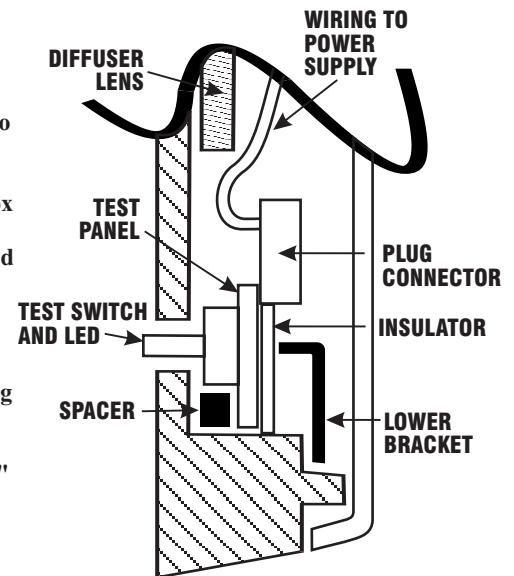

**TEST PANEL ASSEMBLY**

### CHEVRON ARROW SELECTION

1. With backplate removed, place sign face on scratch- free surface.
2. Remove four #8-32 screws and detach two corner brackets and one lower bracket. Retain all screws.
3. Remove lens diffuser and place on scratch- free surface. LED panel and test panel assembly (in battery backup models only) can be left in place.
4. Place sign face down on raised wooden blocks (or other scratch- free surface), and carefully knock out selected chevron with hammer and small punch.
5. Place upper edge of lens diffuser against flexible spacers, compress spacers slightly and lower bottom edge of diffuser into place next to LEDs. Replace three brackets and continue with installation

### TOP OR END MOUNT

1. Follow WALL MOUNT steps 1-3.
2. For battery backup models, connect 2-pin polarized battery plug.
3. See Fig.1 and 2 below. Route LED connector through slot in top of housing and through canopy. Insert 6-32 X 3/4" flat head screws into housing and lock down two nuts firmly. Run flat washers on screws, position canopy, and firmly tighten two lock nuts as shown.
4. Raise sign to J-box, insert excess wiring and plug into center cavity and secure sign assembly with 2 #8-32 color- matched screws supplied.

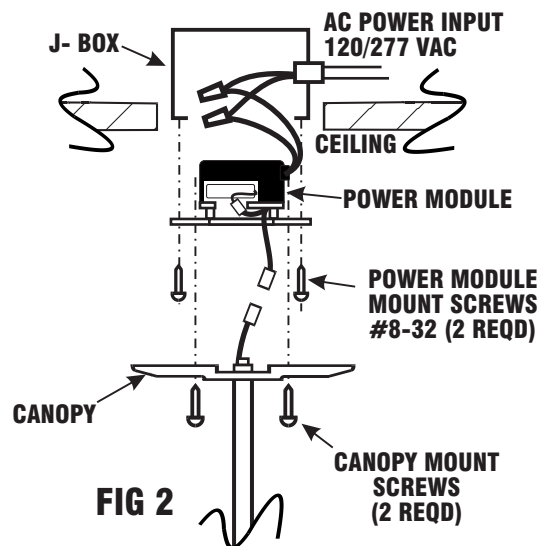
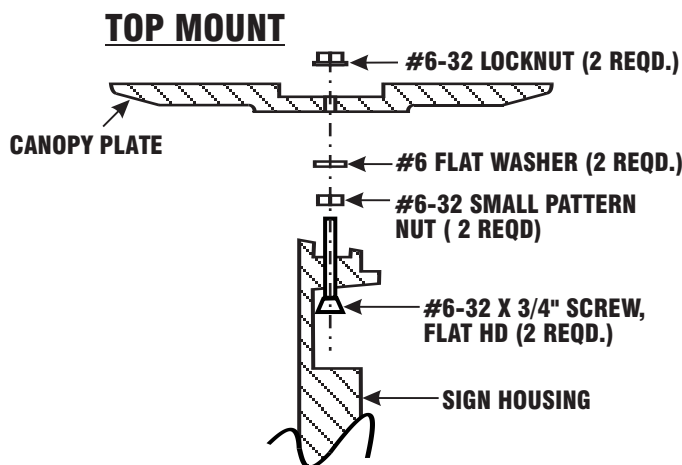

### END MOUNT

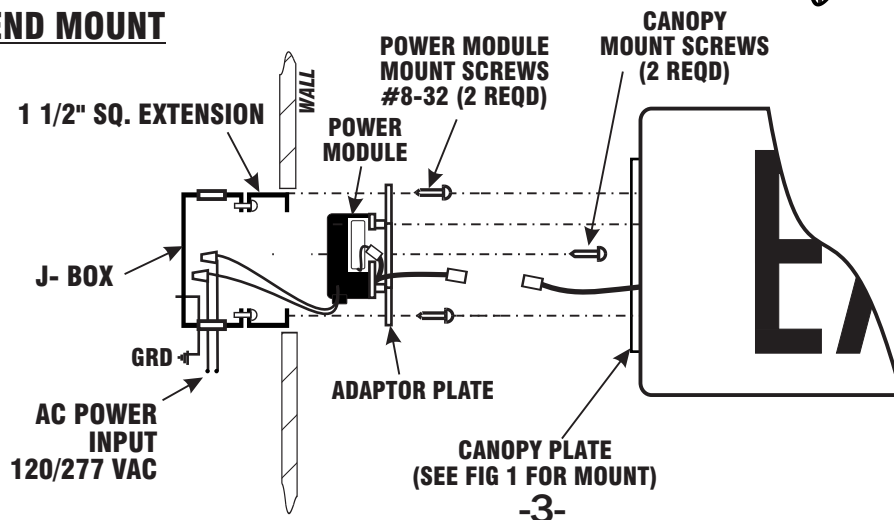

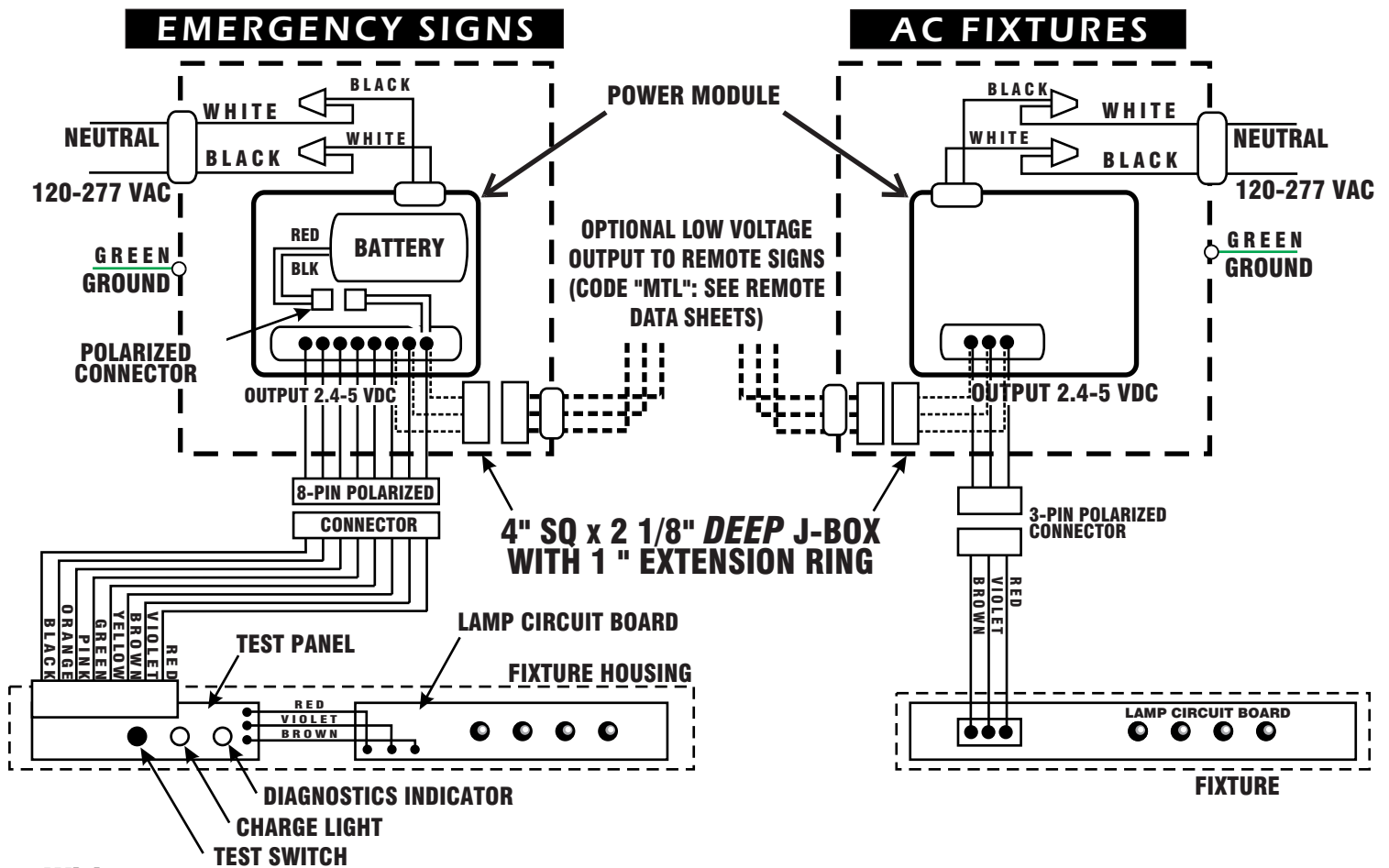

## Wiring

1. This equipment to be connected to an unswitched circuit only.
2. For exits with Master- Remote or Self- Diagnostics, refer to supplementary data sheet for wiring diagrams and additional instructions.
3. **CAUTION:** Damage to battery will occur if battery connector is connected to charger board for prolonged period of time without continuous AC power provided.

## Inspection and Maintenance

**Important Note:** Emergency lighting systems should be tested as often as local codes require, or at least monthly, to ascertain that all components are operational. Allow battery to charge 8 hours before initial testing, and 24 hours to fully charge battery.

1. **Normal Operation:** When unit is functioning properly, with AC power supplied, the "Ready" light and exit lamp will be on.
2. **To Test:** Press manual test switch. "Ready" light will turn off and exit lamp will remain on in DC mode.

**Note:** Turn off AC power and disconnect battery before servicing unit.

## Battery Replacement

Remove fixture from J-Box. Locate battery wiring and disconnect 2-pin polarized battery plug. Pry battery out of cavity to release hook and loop fastener. Replace battery, reconnect battery plug and replace fixture.

## Power Module Replacement

Remove fixture from J-Box. Remove two #8-32 screws to J-Box and remove Power Module Assembly from J-Box. Disconnect wire nuts or push nut connectors to AC line inputs. To replace with new Power Module, reverse this sequence.

REV 07.04.1



**Signtex Inc**  
LIGHTING

220 VFW Avenue, Grasonville, MD 21638

TEL: (410) 827-8300 Fax: (410) 827-8866

sales@signtexinc.com www.signtexinc.com