

INSTALLATION INSTRUCTIONS AND OWNER'S MANUAL

IMPORTANT SAFEGUARDS READ AND FOLLOW ALL SAFETY INSTRUCTIONS

Before connecting to power supply, TURN OFF ELECTRICAL
POWER AT CIRCUIT BREAKER OR FUSE

Disconnect AC power before servicing.

Refer to wiring diagram for proper connections.

All servicing should be performed by qualified personnel.

Consult your local building code for approved wiring and installation.

Do not use outdoors.

Suitable for indoor damp locations (when specified).

Do not let power cords touch hot surfaces.

Do not mount near gas or electric heaters.

Mount and secure exit sign at a location and height to avoid
ready access and tampering by unauthorized persons.

(Exception: Floor proximity installations)

The use of accessory equipment is not recommended by
the manufacturer and may cause an unsafe condition.

Do not use this equipment for other than intended use.



TOP MT
RECESSED



STANDARD
WALL MT



"WATERFALL"
WALL MT



END MT
STANDARD



END MT
FREE LENS

SAVE THESE INSTRUCTIONS

Crystal Recessed Installation Instructions

Series CRR

Before installing or connecting any primary power wiring,
DISCONNECT MAIN POWER SUPPLY AT THE CIRCUIT BREAKER OR FUSE.

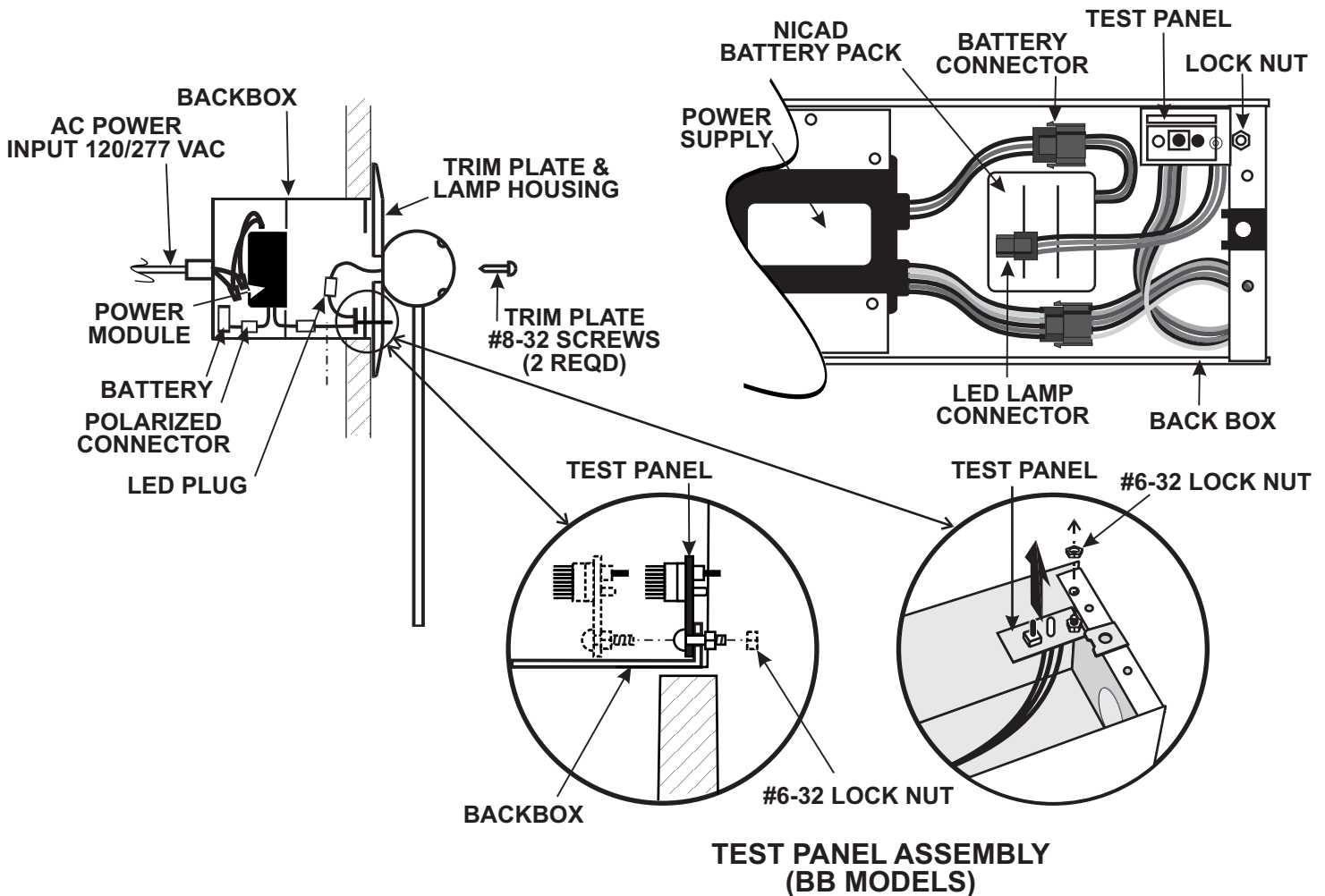

STANDARD WALL MOUNT

1. If power module is supplied separately, secure the module at center of backbox with screws provided.
2. For emergency models, see diagrams above for test panel mount. Insert #6-32 stud into hole in back-box flange, and secure firmly with #6-32 lock nut as shown.
3. Install back-box as required. Edge of back box must be flush or just below finished panel surface.
4. Connect AC wiring to main power lines in back box. BLACK - 120 -277 VAC: WHITE: Common. For battery backup models, connect 3-pin polarized battery plug. Attach building ground wire to backbox with screw provided.
5. Turn ON AC power if available. (NOTE: For battery backup units, LEDs will illuminate on battery power until AC power is connected. Damage to battery may occur if AC power is not supplied for extended periods.)
6. Connect LED plug and position trimplate over backbox.
7. Insert test panel switch and LED through holes in trimplate for battery backup units, then secure assembly with two #8-32 screws supplied.

WATERFALL LENS WALL MOUNT

Crystal Recessed Series CRR

1. Follow standard wall mount procedure steps 1- 5.
2. Connect LED plug. Ensure that all wiring is clear of lamp housing, then secure assembly to backbox with four #6-32 screws supplied.
3. Slide trim plate over lens in position over backbox. For battery backup units, insert test panel switch and LED through holes in trim plate, then secure assembly with two #8-32 screws supplied.

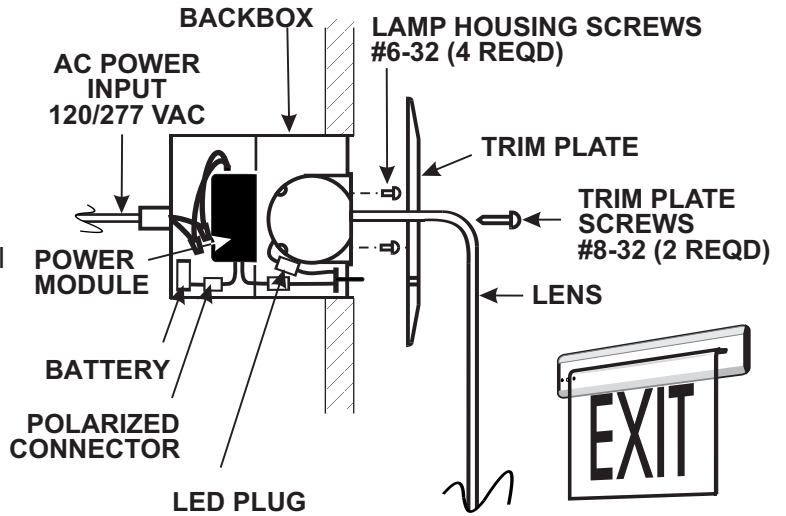

CEILING MOUNT

1. Follow procedure above.

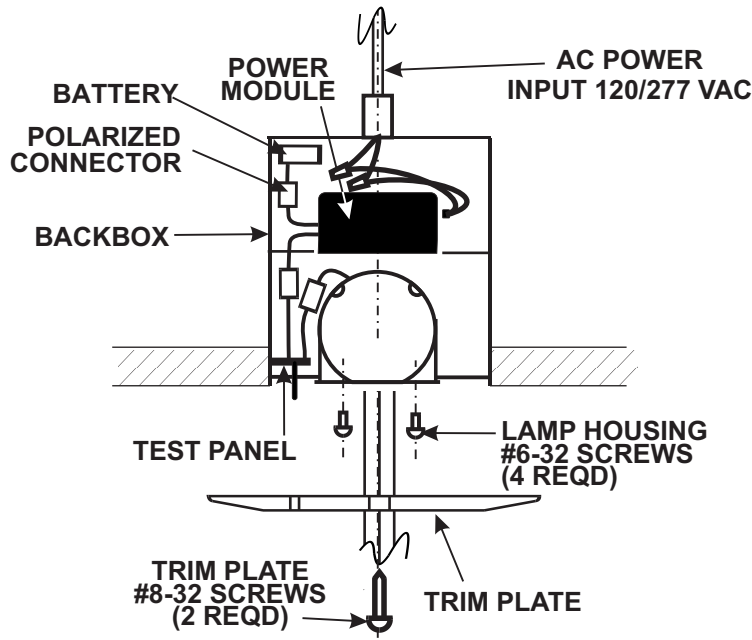

END MOUNT

1. Follow WALL MOUNT steps 1-3 on Page 2.
2. Run LED lamp plug through canopy plate and secure canopy to sign with 2 #6-32 screws supplied.
3. Position sign over j- box, insert excess wiring and plug into center cavity and secure sign assembly with 2 #8- 32 color- matched screws supplied.

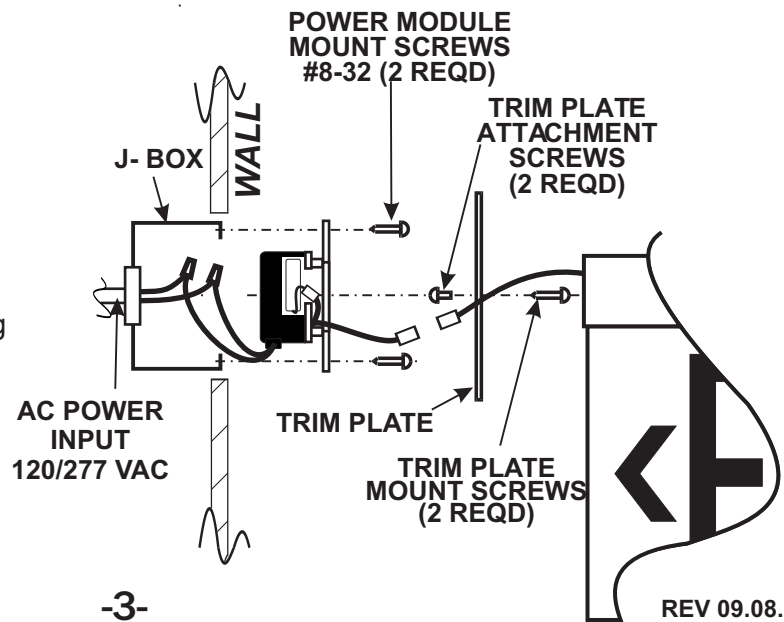

FREE LENS END MOUNT

Crystal Recessed Series CRR

1. Follow standard WALL MOUNT procedure.

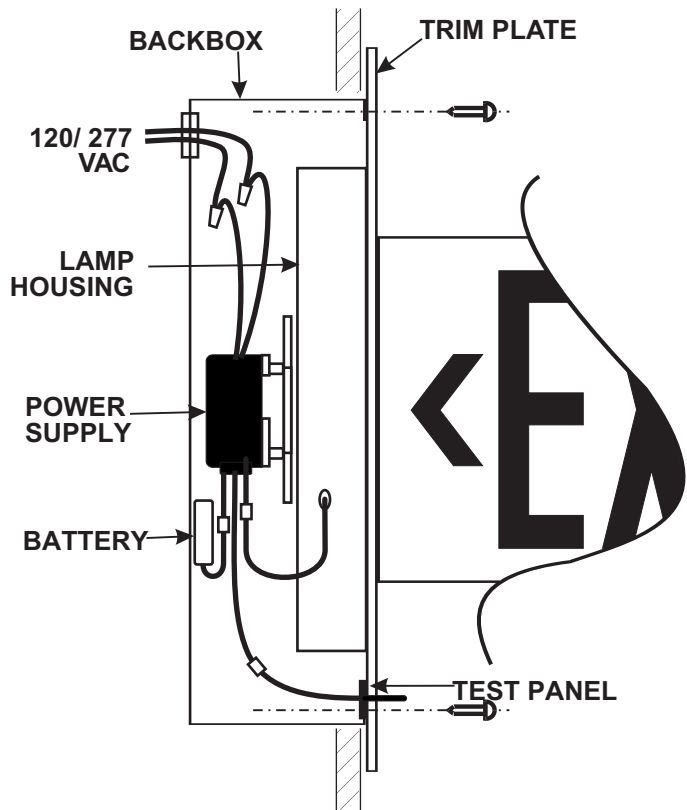
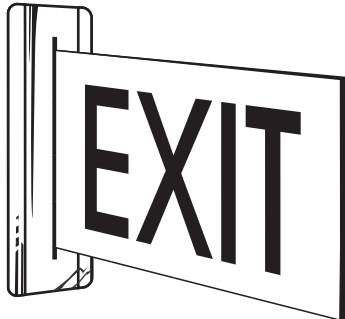

GENERAL

Wiring

1. This equipment to be connected to an unswitched circuit only.
2. For exits with Master- Remote or Self- Diagnostics, refer to supplementary data sheet for wiring diagrams and additional instructions.
3. CAUTION: Damage to battery will occur if battery connector is connected to charger board for prolonged period of time without continuous AC power provided.

Inspection and Maintenance

Important Note: Emergency lighting systems should be tested as often as local codes require, or at least monthly, to ascertain that all components are operational. Allow battery to charge 8 hours before initial testing, and 24 hours to fully charge battery.

1. Normal Operation: When unit is functioning properly, with AC power supplied, the "Ready" light and exit lamp will be on.
2. To Test: Press manual test switch. "Ready" light will turn off and exit lamp will remain on in DC mode.

Note: Turn off AC power and disconnect battery before servicing unit.

Battery Replacement

Remove fixture from J-Box. Locate battery wiring and disconnect 2- pin polarized battery plug. Pry battery out of cavity to release hook and loop fastener. Replace battery, reconnect battery plug and replace fixture.

Power Module Replacement

Remove fixture from J-Box. Remove two #8-32 screws to J-Box and remove Power Module Assembly from J-Box. Disconnect wire nuts or push nut connectors to AC line inputs. To replace with new Power Module, reverse this sequence.



SPECIFIED EMERGENCY LIGHTING
REV 09.08.2